

Finding Angles in Regular Polygons



Section A

- 1) Find the size of each interior angle in a regular hexagon. _____
- 2) Find the size of each interior angle in a regular nonagon. _____
- 3) Find the size of each exterior angle in a regular dodecagon. _____
- 4) Write an expression for the sum of the interior angles in a polygon with n sides. _____
- 5) Write an expression for the size of each interior angle in a polygon with n sides. _____
- 6) Write an expression for the size of each exterior angle in a polygon with n sides. _____

Section B *Find the angles indicated. Each question contains one or more regular polygon.*

1)

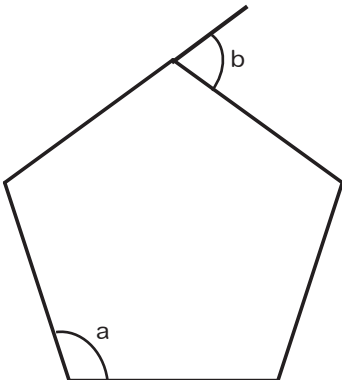

$a =$ _____

$b =$ _____

2)

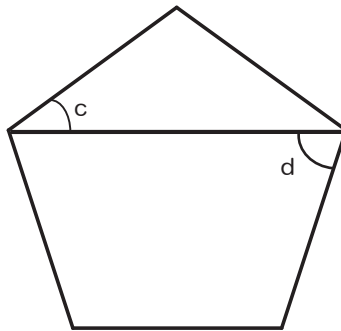

$c =$ _____

$d =$ _____

3)

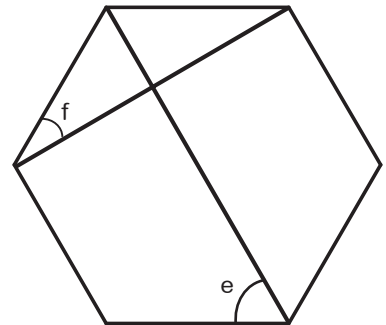

$e =$ _____

$f =$ _____

4)

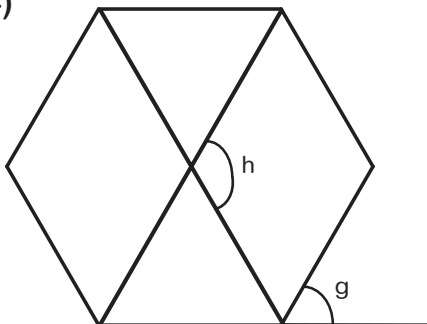

$g =$ _____

$h =$ _____

5)

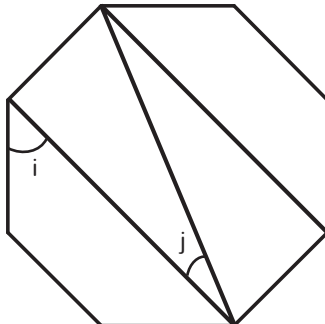

$i =$ _____

$j =$ _____

6)

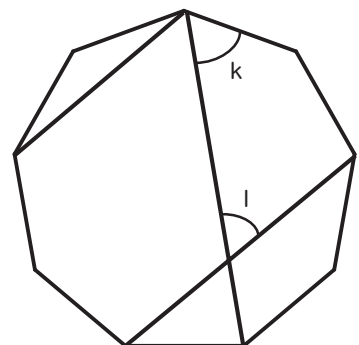

$k =$ _____

$l =$ _____

Finding Angles in Regular Polygons



Section B (con't.)

Find the angles indicated. Each question contains one or more regular polygon.

7)

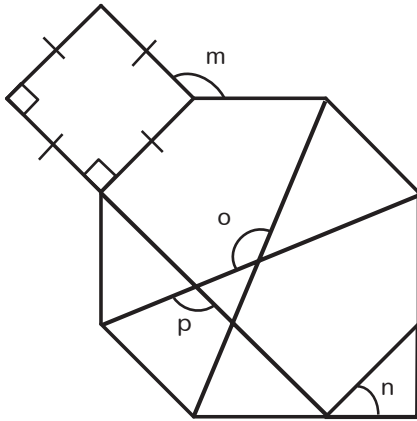

$m = \underline{\hspace{2cm}}$

$n = \underline{\hspace{2cm}}$

$o = \underline{\hspace{2cm}}$

$p = \underline{\hspace{2cm}}$

8)

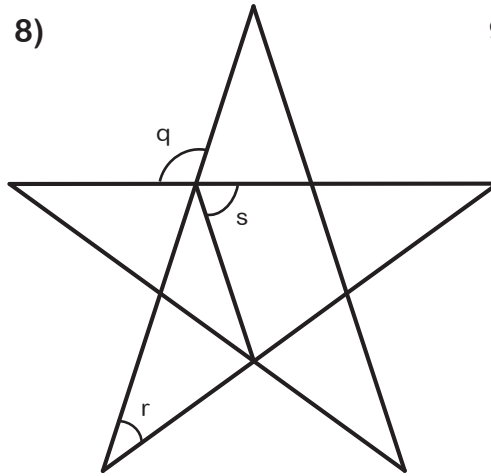

$q = \underline{\hspace{2cm}}$

$r = \underline{\hspace{2cm}}$

$s = \underline{\hspace{2cm}}$

9)

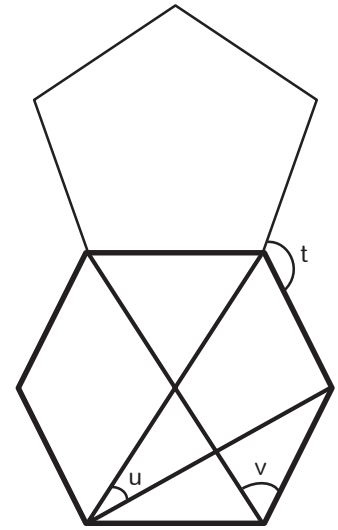

$t = \underline{\hspace{2cm}}$

$u = \underline{\hspace{2cm}}$

$v = \underline{\hspace{2cm}}$

Hint: Look for symmetry in order to assume parallel and perpendicular lines!